



# **INSTALLATION, OPERATION AND MAINTENANCE MANUAL (IOM)**

## **MP SERIES CLOSE-COUPLED MAGNETIC DRIVE SEALLESS PUMPS**



**PHONE (713) 972-8666 / FAX (713) 972-8665**

**3575 West 12<sup>th</sup> Street Houston, TX 77008**

**[www.magnatexpumps.com](http://www.magnatexpumps.com)**

 **DANGER**

## **MAGNETIC DRIVE PUMP**

Do not work on this pump if you are wearing a MEDICAL DEVICE (DEFIBRILLATOR, PACEMAKER, etc.).

Personnel who experience interference with their medical device should move away from the pump and refrain from handling magnetic pump components. Seek immediate medical attention if you have experienced interference with your medical device.

The rare earth permanent magnets in this pump have been manufactured such that the magnetic field is directional toward each half of the magnetic coupling. For this reason, the magnetic field that exists outside of the assembled magnetic coupling is minimal. When the two halves are apart, the magnetic field is exposed, which is why we recommend that personnel wearing medical devices **DO NOT HANDLE** the magnetic coupling components. When the pump is assembled, the magnetic fields from the magnetic coupling components are not exposed and it is safe for those who wear medical devices to be in the general proximity of the assembled pump, whether the pump is in operation or not.

**TABLE OF CONTENTS**

Operating Instructions.....4

Receipt of Equipment.....4

Foundation.....5

Location and Piping.....5

Rotation Check and Start-Up.....7

Priming.....7

Operations and Maintenance.....8

Maintenance Schedule.....9

Storage Procedures.....9

Torque Check.....10

MP Series Parts List.....11

MP Cross Section Drawing.....12

Disassembly of Wetted End.....13

Disassembly of the Outer Magnet and the Motor.....15

Assembly of Wetted End.....16

Assembly of the Outer Magnet and the Motor.....18

Final Assembly.....19

Torque Chart.....20



## **ATTENTION**

### **WHEN WORKING ON MAGNETICALLY DRIVEN PUMPS**

When working on the pumps, be aware that tools or metal parts brought within *proximity* to the magnets may suddenly be attracted, trapping fingers in the process.

## **OPERATING INSTRUCTIONS**

### **MP SERIES CLOSE COUPLED PUMPS**

This instruction manual is intended to help those responsible for the installation, operation and maintenance of **MAGNATEX** Magnetic Drive Sealless Pumps. We recommend thoroughly reading this manual and reviewing the Hydraulic Institute Standards regarding Horizontal Centrifugal Pump installation before installing and operating your pump. Magnatex Pumps, Inc does not assume responsibility from failure to follow the instructions in this manual.

## **RECEIPT OF EQUIPMENT**

- A. Before uncrating, check for potential physical damage to the pump assembly and notify the common carrier IMMEDIATELY if any damage is found.
- B. Check the nameplate on the pump against receiving and purchase order documents to be sure that the correct size pump and materials of construction have been supplied. If a motor has been supplied, check for correct enclosure, horsepower, speed, and voltage. Check to make sure that all accessories are in the package. Installing the wrong pump could result in injury or death and/or damage to the pump.
- C. Check to see if the nozzle protectors are intact as furnished by **MAGNATEX** Pumps. If not intact, check for foreign objects that may have found their way into the pump casing through the flange openings.
- D. Check for free rotation of the pump especially if potential damage in shipping is suspected. Remove the motor fan cover and rotate the pump using the motor shaft. The pump should rotate smoothly and only slight resistance should be felt. If the pump has heavy resistance, or if any noise is heard, call your **MAGNATEX** representative or **MAGNATEX PUMPS, INC.** at (713) 972-8666.

## **FOUNDATION**

The foundation should be firm and heavy to reduce vibration. A concrete foundation with a solid baseplate is recommended.

## **LOCATION AND PIPING**

- A. Locate the pump as close as practical to the source of liquid supply.
- B. The suction line should be as short and straight as possible and contain a minimum number of elbows. Any elbow should be of the large radius type. Elbows and fittings should be no closer than 10 pipe diameters from the pump suction to allow undisturbed flow to the pump impeller. Horizontal suction piping should gradually rise toward the inlet of the pump (minimum gradient of 1/50).
- C. Generally, suction piping should be one or two sizes larger than the pump suction. This will keep friction losses to a minimum. This becomes more important as the distance between the pump and the liquid supply increases, or if fittings are located closer than 10 pipe diameters to the pump's suction.
- D. The suction piping should have no high spots where air pockets can collect. All joints in the suction line should be tight to prevent air from entering into the system and creating the possibility of vapor locking. This is especially important when suction pressure is lower than the atmospheric pressure. A pressure gauge should be installed in the suction line as close as possible to the suction flange.
- E. An air vent should be installed at the initial high point in the pump discharge line. A check valve and shut-off valve should be installed as close as possible to the pump discharge nozzle. The check valve is installed to protect the pump from excessive back pressure, including reverse flow/rotation, and back flow during shut down or driver failure. The discharge valve is at the pump discharge to regulate flow and isolate the pump for servicing. A pressure gauge should also be installed as close as possible to the discharge nozzle between the pump and the discharge valve.

- F. Particles can block the bearing lubrication ports in the pump causing serious damage. In addition, metallic particles can magnetically attach to the inner magnet also resulting in damage. If possible, a temporary start-up strainer with a 40 x 40 mesh screen should be installed in the pump's suction line. **BE VERY CAREFUL** not to allow the temporary strainer to be plugged to the point of starving the pump of liquid. This may result in cavitation and the possibility of running the pump dry which will destroy the pump's silicon carbide bearing system. It is recommended to install a pressure gauge between the strainer and the pump to monitor possible plugging of the strainer. The discharge pressure should also be closely monitored. Any drop in discharge pressure without adjusting the discharge valve could suggest strainer plugging (assuming constant demand to the system).
- G. **MAGNATEX** pumps, although very rugged, are not designed to handle pipe stress. The resulting forces and moments can result in possible damage to the pump. Piping must be anchored and supported as close as possible to, but independent from the pump. Pump and pipe flanges must be positioned together without using force before attempting to tighten the flange bolts.

H.



Adequate liquid should always be available to the pump suction. A flow sensor and/or watt monitor should be installed to shut the pump down in the event of dry run. **MAGNATEX** provides an optional Electronic Pump Protector (PMP-25 and PMP-25V), which we recommend you purchase.

## **ROTATION CHECK AND START-UP**

 **DANGER** 

**ONLY PROPERLY QUALIFIED PERSONNEL SHOULD BE  
WORKING ON PUMPS OR ELECTRIC MOTORS**

To confirm the direction and rotation against the rotation arrow on the pump casing use the following procedure:

- A. Open the suction and discharge valve and allow the pump to be filled with liquid. Do not attempt to bump the motor to check rotation without liquid in the pump.

 **WARNING** 

**NEVER RUN THE PUMP DRY**

- B. Remove the motor fan cover for visual inspection rotation.
- C. Bump the motor by quickly pushing the motor start/stop buttons. Rotation should be clockwise as seen from motor end. If the direction of rotation is incorrect, reverse two of the three-phase power leads to the motor. Keep your hands away from the fan motor to avoid injury.
- D. After confirming proper rotation replace the motor fan cover.

## **PRIMING**

- A. Open the suction and discharge valves and allow the pump to fill with liquid. If the direction of rotation has not been checked, this must be done as detailed above.

 **WARNING** 

**NEVER RUN THE PUMP DRY**

- B. Close the discharge valve to 1/4 open.
- C. Start the motor and immediately check the discharge pressure gauge. The pressure

should rise quickly and hold steady. If the pressure rises and then falls back, there is air or vapor in the system. **STOP THE PUMP IMMEDIATELY.** Wait 15 to 20 seconds before restarting the pump.

- D. If after repeating Step C several times, the pressure gauge does not hold steady or does not yield the expected pressure (from performance curve), contact your Magnatex representative, or MAGNATEX PUMPS, INC., for assistance. Do not continue to operate the pump under these conditions.
- E. Once the pump is fully primed and the discharge pressure is satisfactory, slowly open the discharge valve until the desired operation point is reached. Stop the pump immediately if you hear any unusual noises or vibration and call MAGNATEX PUMPS at 1-866-624-7867.

## **OPERATIONS AND MAINTENANCE**

- A. Operators should make frequent visual inspections to insure the pump is running smoothly without noise or vibration. The discharge pressure should hold steady without fluctuation. Any excessive heating of the pump or motor bearings is cause for alarm. The unit should be shut down immediately, an investigation made to find the cause, and corrective action taken.
- B. Follow the motor manufacturer's recommendations and keep the motor bearings lubricated properly.

### **WARNING**

**Never throttle the pump by closing the valve on the suction side of the pump. Throttling the suction side can cause serious damage to the pump. Throttle only from the discharge valve.**

### **WARNING**

**Never operate the pump against a closed discharge valve. Low flow operation can cause rapid heating of the pumped liquid with possible vaporization of the liquid inside the pump, resulting in serious damage to the pump.**

## **MAINTENANCE SCHEDULE**

### **PARTS TO BE INSPECTED**

<b><u>Inspect</u></b>		<b><u>Frequency</u></b>
<b>Inner Magnet Sub-Assembly</b>	<b>Check Thrust Rings, Sleeves, and Bushings for wear. Use a dye penetrant test and replace any chipped, cracked or broken pieces. Use new casing gasket upon reassembly.</b>	<b>Every 2 to 3 years (depending on service).</b>
<b>Motor</b>	<b>As recommended by the motor manufacturer.</b>	<b>As directed in the motor operations manual.</b>

## **STORAGE PROCEDURES**

As shipped, the pumps are suitable for short term storage only, up to 3 months. If long term storage is necessary before the pump is put into operation, contact your local representative or **MAGNATEX PUMPS**, for long term storage recommendations.

For maximum protection, cover the pump with plastic or another protective material. Motors should be rotated by hand every three (3) months.

Before start-up, refer to the section titled "Rotation Check and Start-Up" (see Page 7).

## **TORQUE CHECK**

To determine the static breakaway torque of the magnet couplings, place a torque wrench on the impeller nut and hold the motor fan shaft with locking pliers. Slowly turn the torque wrench counterclockwise (as seen from motor end) until the magnets turn over (decouple). The preferred method for checking torque is to insert the torque wrench through the suction nozzle, leaving the casing attached to the pump [Fig. 1]. Minimum torque values are as follows:

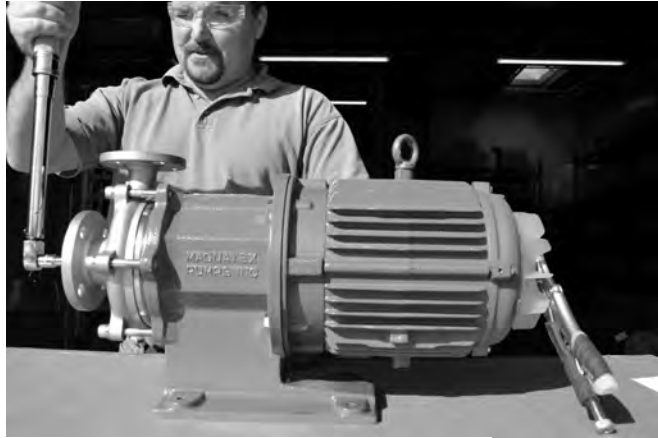

Figure 1

## **MINIMUM MAGNET TORQUE VALUES:**

<b><u>Magnet Size</u></b>	<b><u>Minimum Torque (ft-lb)</u></b>
N25	6.3
N40	10.6

**MP SERIES PARTS LIST**

No.	Part	Material	Qty.	Remark
76	Set screw	Steel	1	M8 x 8L
66	Hex socket head cap screw (casing)	304SS	6	M10
(64)	Flange bolts (hex head bolt)	304SS	4	M10 (MPH, ML ONLY)
50	Frame adapter	Cast Iron	1	
48	Magnet	RARE EARTH	1	
	Magnet coupling (outer)	Iron	1	
44	Thrust ring	SiC	2	AMH-200000-29S
43	Sleeve	SiC-X	2	AMH-20000-9D
42	Bushing	SiC	2	AMH-20000-45S
40	Magnet	RARE EARTH	1	
	Magnet coupling (inner)	316SS	1	
33	Sheet gasket		1	1.5t
(18)	Flange Adapter	CF-8	1	(MPH and ML only)
17	Pin	316SS	2	φ3 x 8L
16	Coupling key	316SS	1	
15	Impeller key	316SS	1	
14	Plug	316SS	1	R 3/8
8	Hex socket head cap screw	316SS	4	M5 x 0.8 x 10L
6	Impeller nut	316SS	1	M12
5	Shaft	316SS	1	
4	Rear casing	316SS	1	
3	Casing cover	316SS	1	
2	Casing	316SS	1	
1	Impeller	316SS	1	

Note: Material for standard 316SS wetted parts construction. Other materials are available. Always provide pump serial number when ordering replacement parts.

### **MP SERIES CROSS SECTION DRAWING**

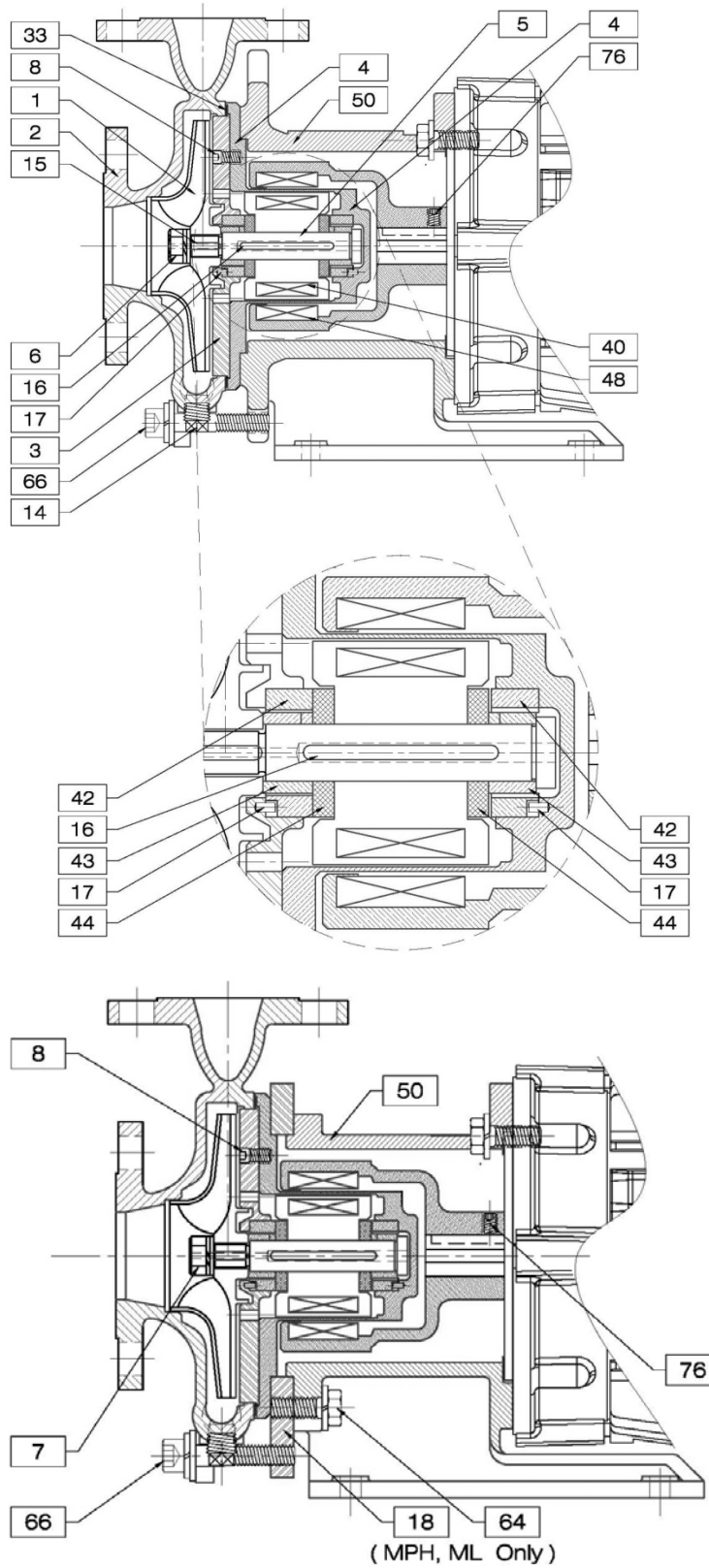

## DISASSEMBLY OF WETTED END

1. Remove the casing drain plug (Item 14) and empty the pump of any remaining liquid. Thoroughly flush the pump; beware of small amounts of liquid that will remain in the pump, particularly in the rear casing. Always wear protective equipment when working with hazardous chemicals.

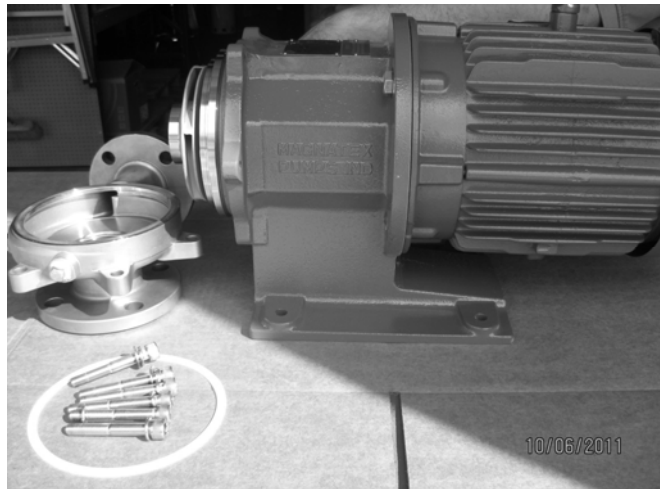

Figure 2

2. Remove the six casing hex socket head cap screws (Item 66) [Fig. 2] and set the casing to one side.

3. Set the pump and motor assembly on the motor fan cover. Remove the casing gasket (Item 33).



Figure 3

4. Pull the rear casing and impeller assembly from the frame adapter (Item 50) [Fig. 3]. During this procedure, remember that strong magnetic forces are working to keep the inner and outer magnets together, so be careful to keep your fingers from getting trapped.

### **⚠ WARNING ⚠**

**BE CAREFUL TO AVOID TRAPPING YOUR FINGERS BETWEEN THE IMPELLER AND REAR CASING ASSEMBLY AND THE FRAME ADAPTER.**

5. Remove the impeller nut (Item 6), washers, impeller (Item 1), and impeller key (Item 15) [Fig. 4].



Figure 4

6. Remove the four hex socket head cap screws (Item 8) on the casing cover (Item 3) [Fig. 5].

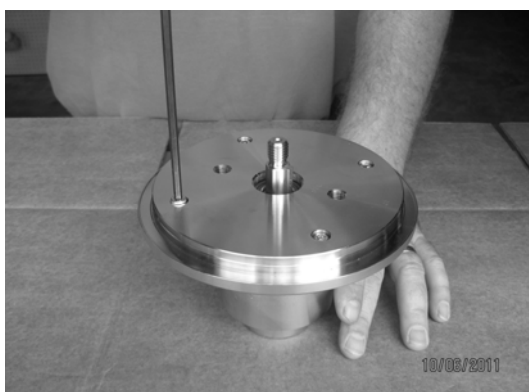

Figure 5

7. Carefully lift off the casing cover (Item 3). Both the bushing (Item 42) and the sleeve (Item 43) are now loose and may come out with the casing cover. Since both parts may be damaged if dropped, be prepared to hold them as the casing cover clears the shaft (Item 5) [Fig. 6].

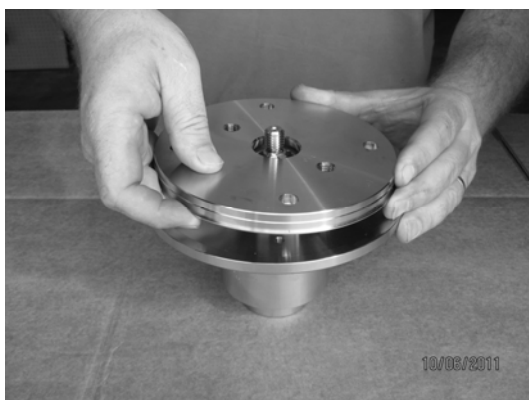

Figure 6

8. Remove the bushing (Item 42) from the casing cover (Item 3). The bushing pin (Item 17) may become loose during disassembly.

- Vertically remove the shaft (Item 5) and inner magnet (Item 40) [Fig. 7]. Be careful of the loose bushing (Item 42) at the bottom of the rear casing. The bushing pin (Item 17) may become loose during disassembly.



Figure 7

- Remove the sleeves (Item 43), thrust rings (Item 44), the inner magnet (Item 40) and the inner magnet key (Item 16) from the shaft (Item 5) [Fig. 8].



Figure 8

### **DISASSEMBLY OF THE OUTER MAGNET AND THE MOTOR**

- Remove the four hex head bolts that hold the frame adapter (Item 50) to the motor [Fig. 9]. Remove the frame adapter.
- Loosen the outer magnet set screw (Item 76), and pull the outer magnet (Item 48) off the motor shaft. [Fig. 10].



Figure 9

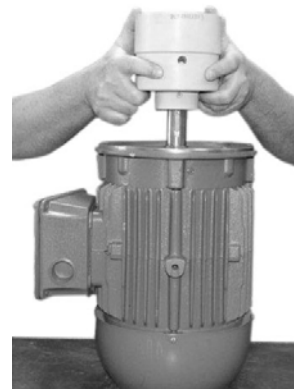

Figure 10

### **ASSEMBLY OF WETTED END**

1. Slide a sleeve (Item 43) onto the inner magnet shaft (Item 5) so that the notch will fully expose the keyway. Place the inner magnet key (Item 16) into the inner magnet shaft keyway. Slide a thrust ring (Item 44) onto the shaft (Item 5). Check that all contact surfaces are properly aligned with each other. [Fig. 11].
2. Slide the inner magnet (Item 40) onto the shaft with stamped word "Front" facing toward the threaded end of the shaft [Fig. 12].
3. Slide a thrust ring (Item 44) onto the inner magnet shaft (Item 5) and over the inner magnet key (Item 16). Slide a sleeve (Item 43) onto the shaft, so that the notch fits over the inner magnet key. Mark the edge of the sleeve opposite the notch with a pencil or ink pen. Check that all contact surfaces are properly aligned with each other [Fig. 13].
4. Check if bushing pin (Item 17) is securely in place in the rear bearing holder in bottom of the rear casing (Item 4). A center punch may be used to prevent loosening [Fig. 14].

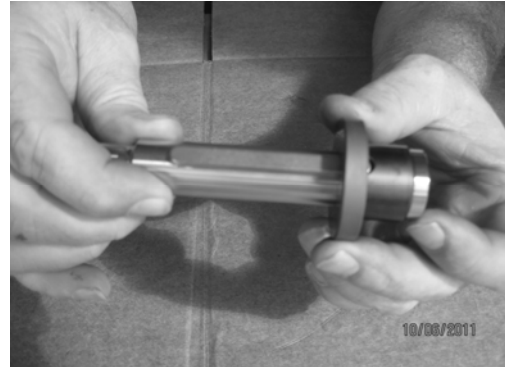

Figure 11



Figure 12



Figure 13



Figure 14

5. Place a bushing (Item 42) into the bearing holder in the bottom of the rear casing (Item 4) and engage the bushing pin (Item 17) with the notch on the bottom of the bushing. Carefully slide the inner magnet shaft (Item 5), with the inner magnet, sleeves and thrust rings on it, into the rear casing [Fig. 15]. Be sure to keep the pencil or pen mark in line with the impeller keyway on the shaft.



Figure 15

6. Set the rear casing subassembly at a 45 degree angle. Place a bushing (Item 42) into the casing cover (Item 3) and engage it to the bushing pin (Item 17) with the notch on the bottom of the bushing. While keeping the “UP” stamped on rear casing and casing cover in line with each other and holding the front bushing in place, guide the casing onto the inner magnet shaft and into the rear casing (Item 4) [Fig. 16].

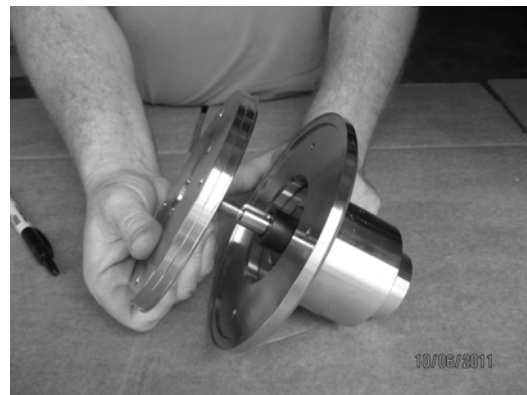

Figure 16

7. Bolt the casing cover (Item 3) onto the rear casing (Item 4) using the four hex socket head cap screws (Item 8). Tighten evenly to avoid binding [Fig. 17]. (See Torque table Page 20).



Figure 17

8. Place the impeller key (Item 15) into the keyway on the inner magnet shaft (Item 5). Keep pencil or pen mark in line with impeller key keyway. Slide the impeller (Item 1) onto the shaft; be careful not to allow rotation of the shaft. While holding the impeller in place to keep the shaft from rotating, bolt into place with the impeller nut (Item 6). (See Torque table Page 20). Check for free rotation of the assembly. This completes the PB rotating assembly [Fig. 18].



Figure 18

### **ASSEMBLY OF THE OUTER MAGNET AND THE MOTOR**

1. Place the motor key (Item 87) into the keyway on the motor shaft, slide the outer magnet (Item 48) into place and tighten the outer magnet set screw (Item 76) [Fig. 19]. (See Torque table Page 20). Make sure that the end of the motor shaft is flush with the bottom of the outer magnet assembly.



Figure 19

## **FINAL ASSEMBLY**

1. Slide the impeller and rear casing assembly [Fig. 18] into the frame adapter (Item 50) [Fig. 20].
2. Place a NEW gasket (Item 33) onto the rear casing (Item 4) and bolt the casing (Item 2) to the adapter with the six hex socket head cap screws (Item 66). [Fig. 21].
3. Tighten the socket head cap screws (Item 66) evenly to avoid binding. (See Torque table Page 20).
4. Tighten the casing drain plug (Item 14) into the casing (Item 2).
5. Lower the pump assembly into the motor and outer magnet assembly [Fig. 22].



Figure 20

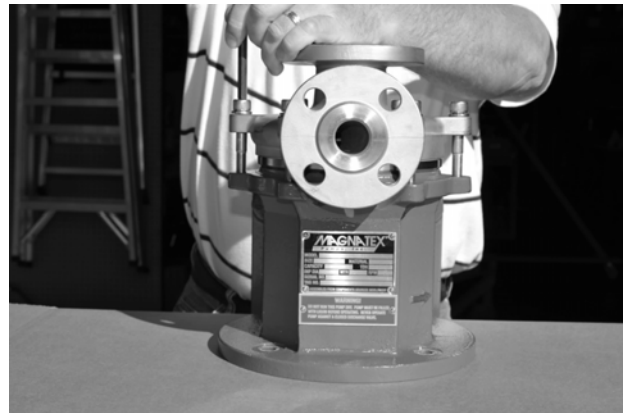

Figure 21



**WARNING**



**BE CAREFUL TO AVOID TRAPPING YOUR FINGERS  
BETWEEN THE PUMP END ASSEMBLY AND THE  
MOTOR FLANGE.**

6. Be sure that the stamped “UP” on frame adapter (Item 50) and rear casing (Item 4) are in line with each other and are directly opposite the pump base. Bolt the frame adapter to the motor flange with the four hex socket head cap screws (Item 63). (See Torque table Page 20).



Figure 22

7. Check for free rotation of the pump and motor assembly by turning the motor fan. If resistance, scraping or grinding is felt, or if noise is heard, dismantle and inspect the pump and take corrective action.
  
8. While the motor fan cover is off, torque check the pump magnets (see Page 10) [Fig. 1]. If the magnets decouple below minimum torque value, the magnets should be replaced.

**OPTIMAL TIGHTENING TORQUE FOR BOLTS AND NUTS**

Part No.	6	8	66	76	64
Part Pump Size	Impeller Nut	Hex Socket Head	Casing Bolts (Hex Socket Head)	Set Screw	Flange Bolts (Hex Head Bolts)
210					
220	M12	M5	M10	M8	M10
221					
222	260.2 in/lbs.	25.7 in/lbs.	212.4 in/lbs.	53.1 in/lbs.	212.4 in/lbs.
420	22 ft/lbs.	2.2 ft/lbs.	18 ft/lbs.	4.4 ft/lbs.	18 ft/lbs.
421	29.4N-m	2.9N-m	24N-m	6.0N-m	24N-m
541	3.0kgf-m	0.29kgf-m	2.45kgf-m	0.61gf-m	2.45kgf-m
542					( MH, ML Only)